

BUKH DV 36 SME - TECHNICAL DATA

A BUKH saildrive distinguishes itself from others in a number of important features:

- A very strong double diaphragm keeps the water out. A sensing element has been installed between the diaphragm which releases an audible alarm at the slightest indication of water penetration.
- All materials - including bolts and diaphragm flanges - are rustproof and saltwater resistant.
- A newly developed multiple-disc clutch ensures smooth engagement of gears and can stand brutal shifts from forward to reverse
- Specially cut conical gears ensure noiseless power transmission.

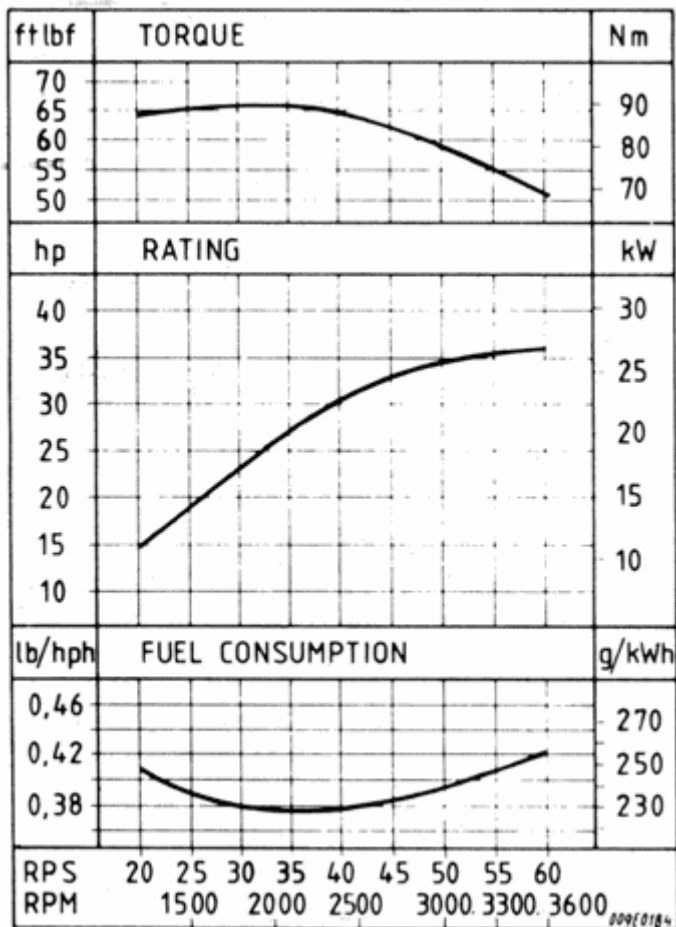

Max intermediate rating at 66 rpm (4000 rpm)	39 HP (28.7 kW)
Continuous rating (DIN 6270B) at:	
60 rps (3600 rpm)	36 HP (26.5 kW)
50 rps (3000 rpm)	31 HP (23.1 kW)
40 rps (2400 rpm)	25 HP (18.6 kW)

Saildrive with reverse-reduction gear ratio	2.25:1
Engine rotation (looking forward)	Anti-clockwise
Propeller rotation (looking forward)	Anti-clockwise
Number of cylinders	3
Bore x stroke	3.35 x 3.35 in (85 x 85 mm)
Stroke volume	88.29 cu in (1447 cm ³)
Operating principle	4-stroke, diesel
Combustion system	Direct injection
Cooling system (standard)	Direct seawater
Max inclination - fore and aft	15°
Max heel - continuous	30°
Fuel consumption	
	full load 2.11 galls/h (8 l/h)
	cruising 1.24 galls/h (4.7 l/h)
Electric starter motor	12V - 1.74 HP (1.3 kW)
Charging alternator	14V, 50Amp, 700W
Net weight	
	639 lbs (290 kg)
including freshwater cooling	683 lbs (310 kg)

STANDARD EQUIPMENT:

- Saildrive with reverse-reduction gear
- Wet sump lubrication system
- Pre and main (full flow) filter
- Bosch distributor injection pump with automatic timing device and governor
- Automatic ventilation of fuel system
- Seawater cooling with thermostat
- Watercooled exhaust manifold
- Lubricating oil cooler
- Air inlet filter and silencer
- Fuel lift pump
- Remote operating panel with: Charging light, luboil pressure warning light, cooling water temperature warning light, key switch for start and stop and audible warning
- Electric start and charging alternator
- Zinc anode protection
- Engine plinth
- Fittings for remote control
- Standard set of tools
- Drain pump for luboil
- Flexible engine mounts
- Watercooled exhaust bend
- Operating manual

SCHEMATICS:

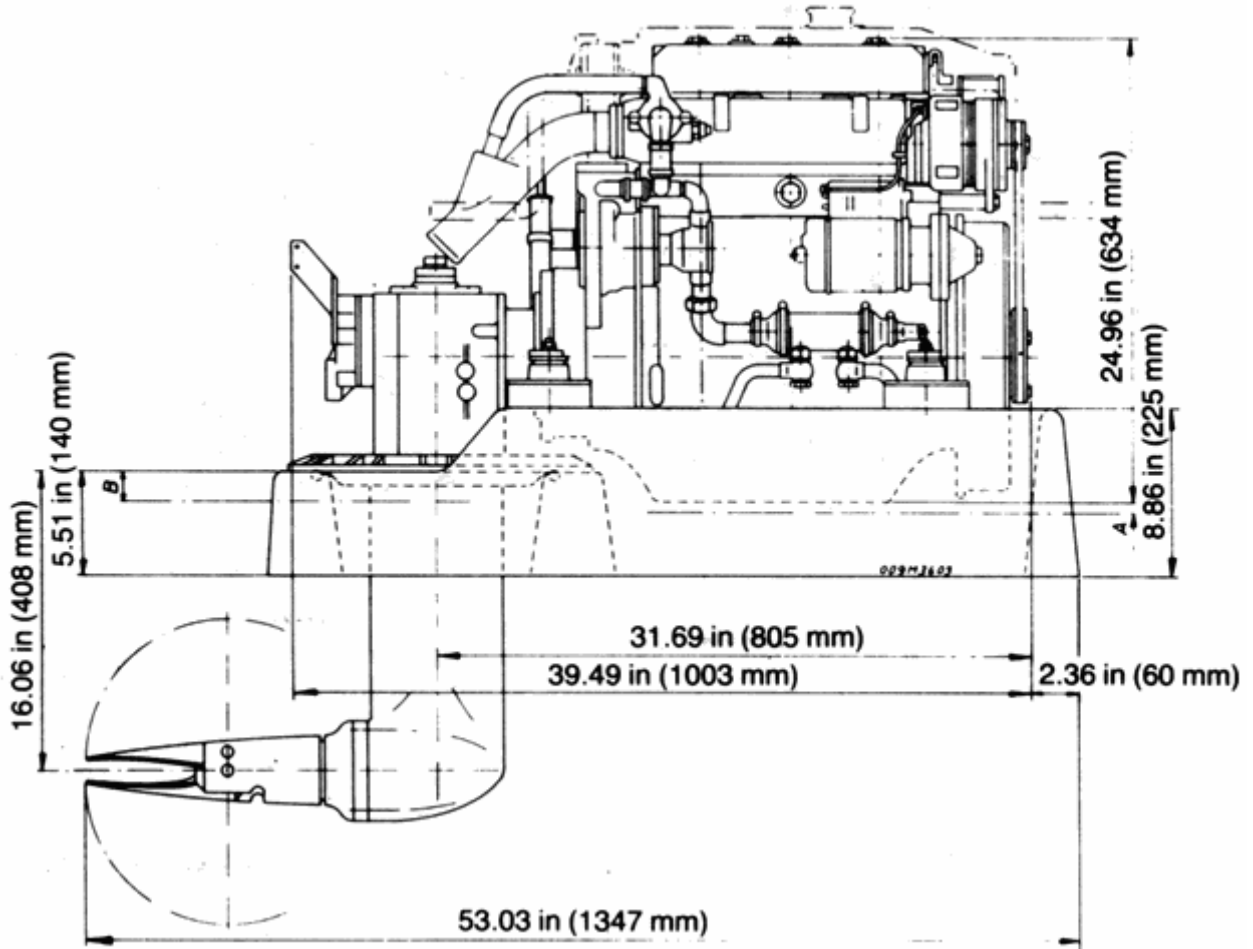

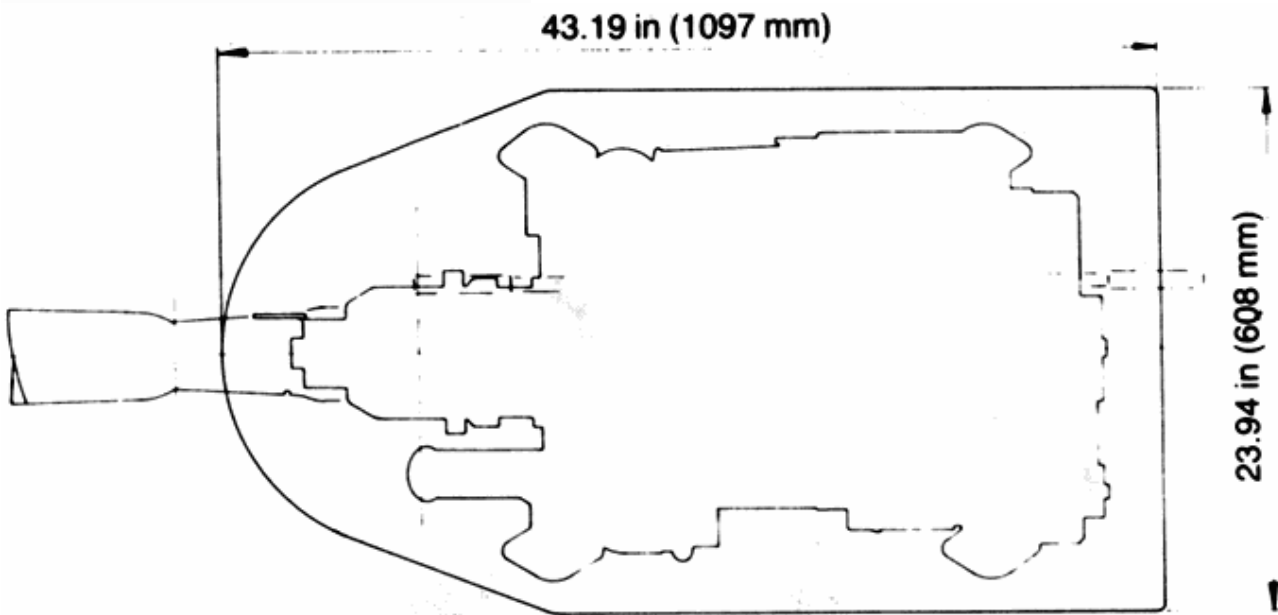
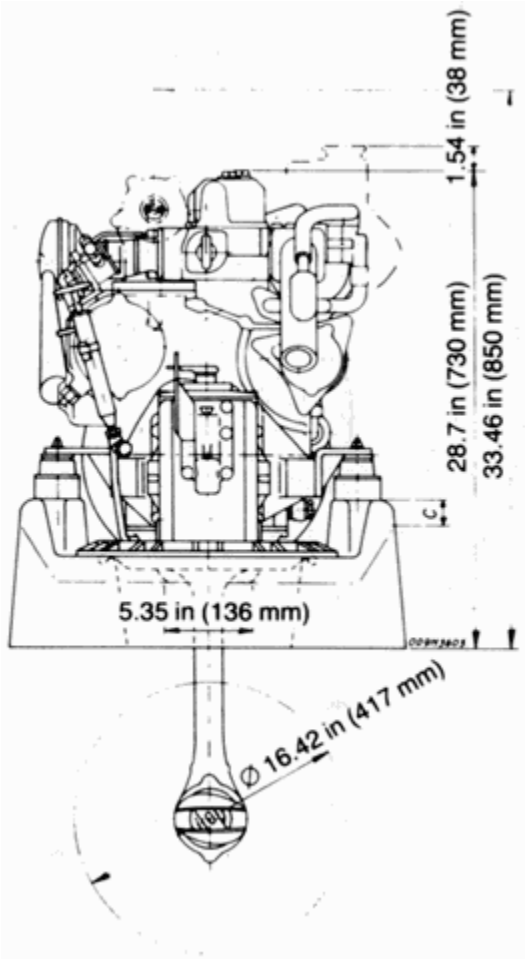

BUKH is always endeavouring to improve the engines, therefore specifications mentioned are subject to alterations without previous notice