

BUKH DV 36 ME - TECHNICAL DATA

When first introduced the BUKH's 36 HP marine diesel was described as the best marine diesel in the world because it was so quiet and smooth.

Today -

- It is still the engine that has the lowest noise level.
- It is still completely free from vibrations.
- It is still a thorough marine diesel created for use in saltwater environment.
- It has a very low fuel consumption.

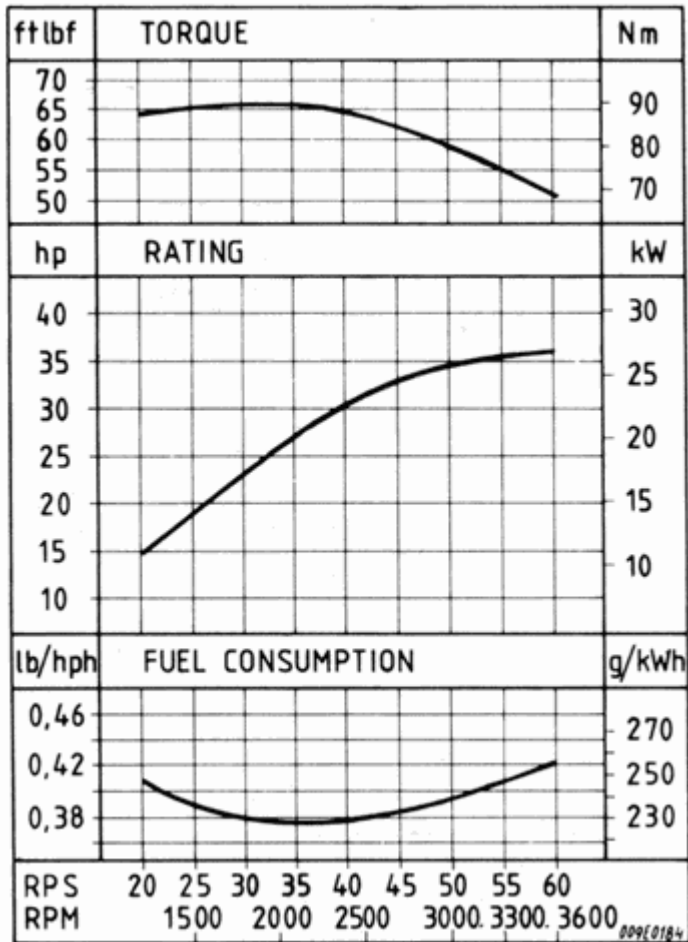
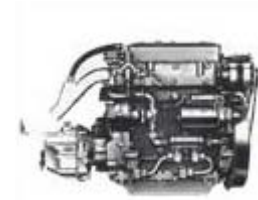

With a DV 36 the larger sailing yachts, motor sailers and displacement boats can get the same comfort as boats with smaller BUKH engines.

Max intermediate rating at 66 rpm (4000 rpm)	39 HP (28.7 kW)
Continuous rating (DIN 6270B) at:	
60 rps (3600 rpm)	36 HP (26.5 kW)
50 rps (3000 rpm)	34 HP (25.0 kW)
40 rps (2400 rpm)	30 HP (22.0 kW)
Reverse-reduction gear ratio	3:1
Engine rotation (looking forward)	Anti-clockwise
Propeller rotation (looking forward)	Clockwise
Number of cylinders	3
Bore x stroke	3.35 x 3.35 in (85 x 85 mm)

Stroke volume	88.29 cu in (1447 cm ³)
Operating principle	4-stroke, diesel
Cooling system (standard)	Direct seawater
Max inclination - fore and aft	15°
Max heel - continuous	30°
Fuel consumption	
full load 60 rps	2.11 galls/h (8 l/h)
cruising	1.24 galls/h (4.7 l/h)
Electric starter motor	12V - 1.74 HP (1.3 kW)
Charging alternator	14V, 50Amp, 700W
Net weight	
	584 lbs (265 kg)
including freshwater cooling	628 lbs (285 kg)

STANDARD EQUIPMENT:

- Reverse-reduction gear
- Wet sump lubrication system
- Pre and main (full flow) filter
- Bosch distributor injection pump with automatic timing device and governor
- Automatic ventilation of fuel system
- Seawater cooling with thermostat
- Watercooled exhaust manifold
- Lubricating oil cooler
- Air inlet filter and silencer
- Fuel lift pump
- Remote operating panel with: Charging light, lubeoil pressure warning light, cooling water temperature warning light, key switch for start and stop and audible warning
- Electric start and charging alternator
- Zinc anode protection
- Fittings for remote control
- Standard set of tools
- Drain pump for lubeoil
- Flexible engine mounts
- Watercooled exhaust bend
- Operating manual

SCHEMATICS:

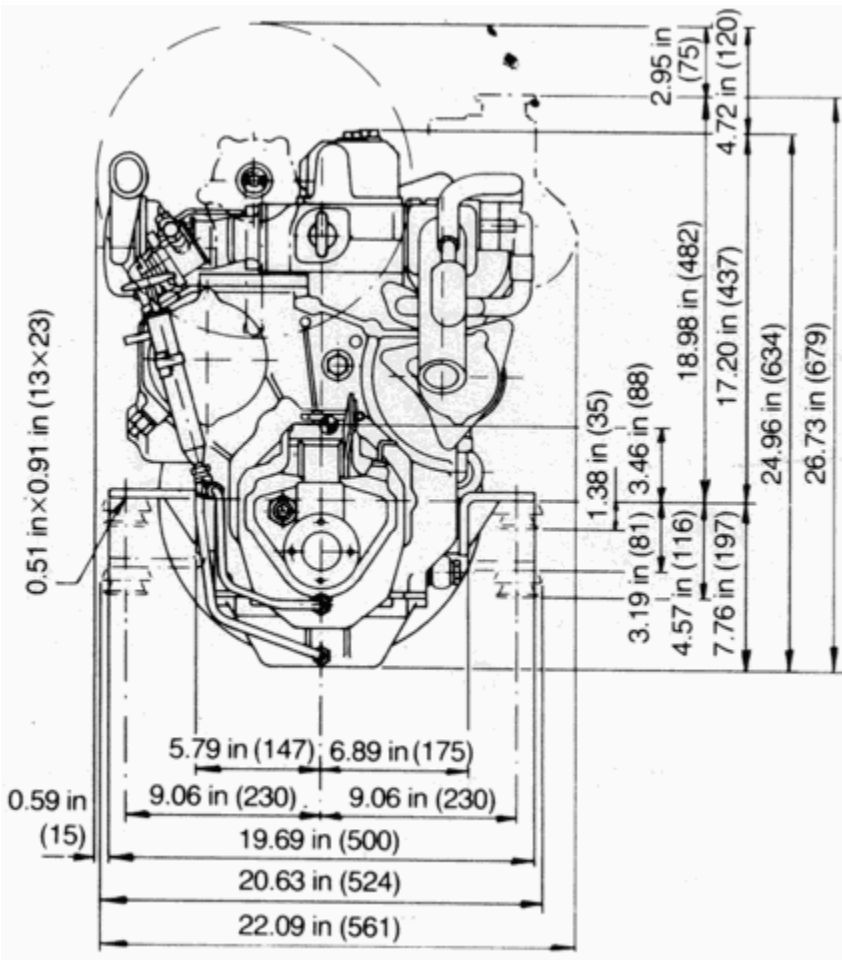
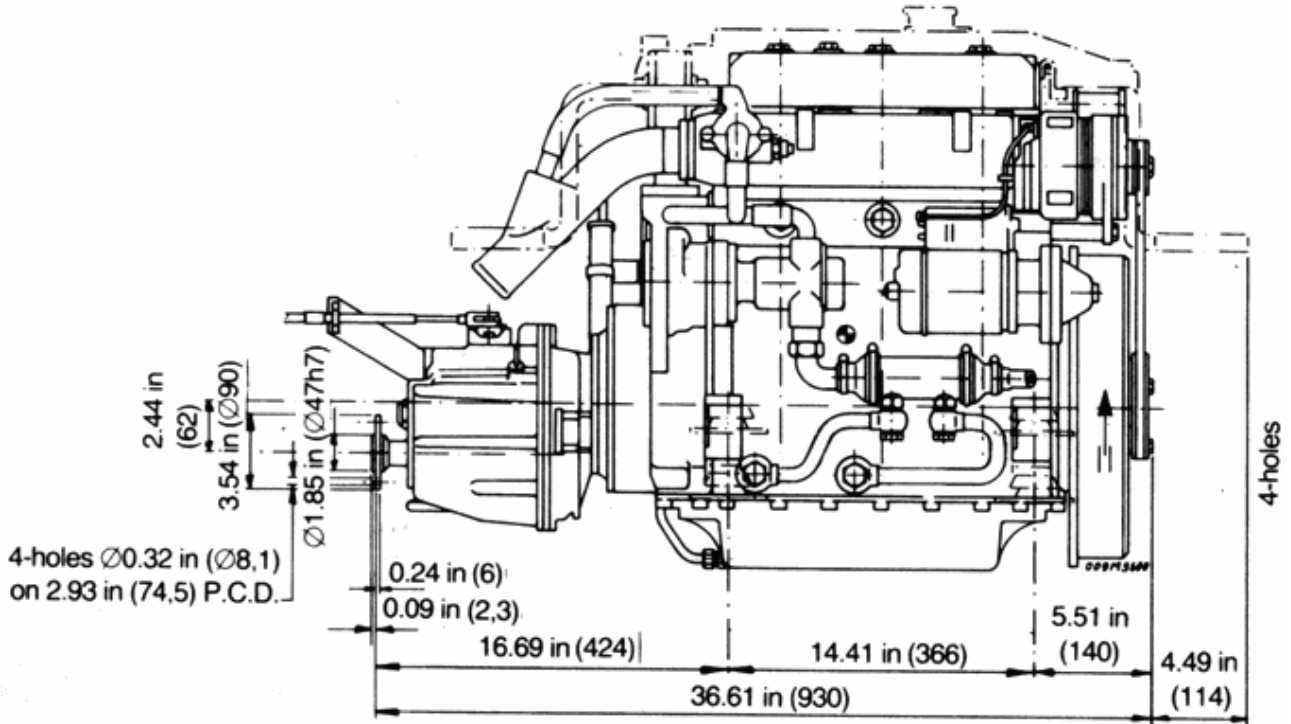

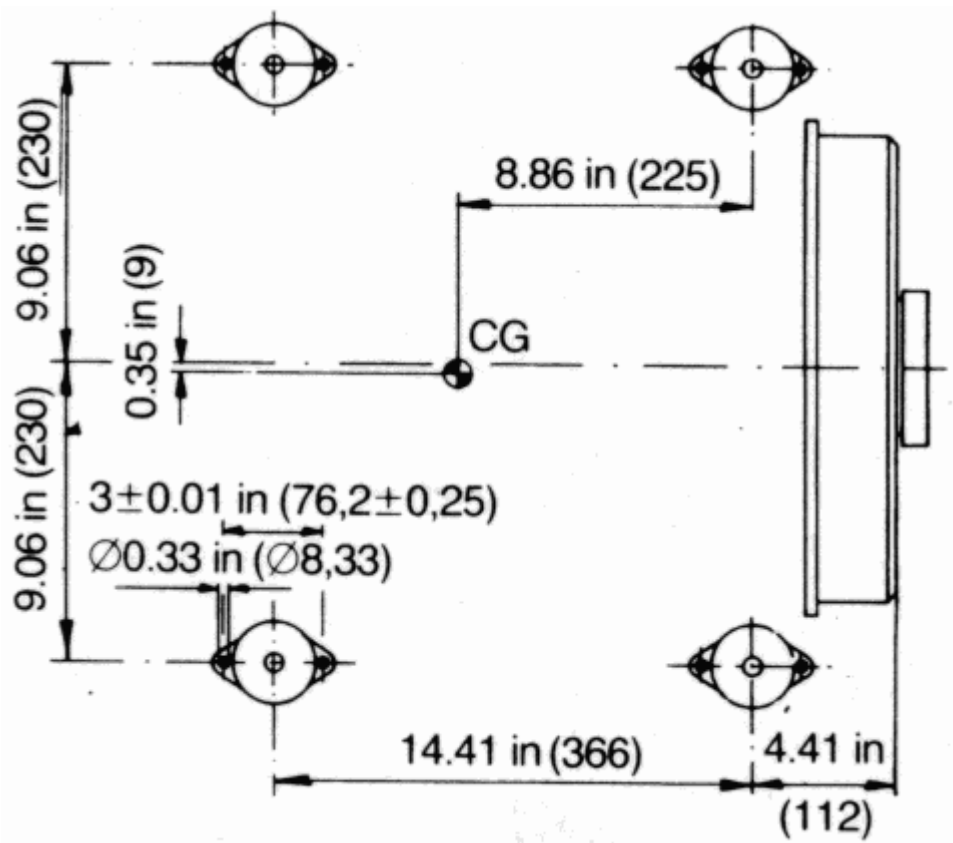

BUKH is always endeavouring to improve the engines, therefore specifications mentioned are subject to alterations without previous notice.